



# Distribution Valves

## Sizes: 2" through 12"



T. D. Williamson, Inc.

Bulletin No: 2010.001.01

Date: February 2000

Cross Indexing No: n/a

Supersedes: 2010.001.00 (2/99)

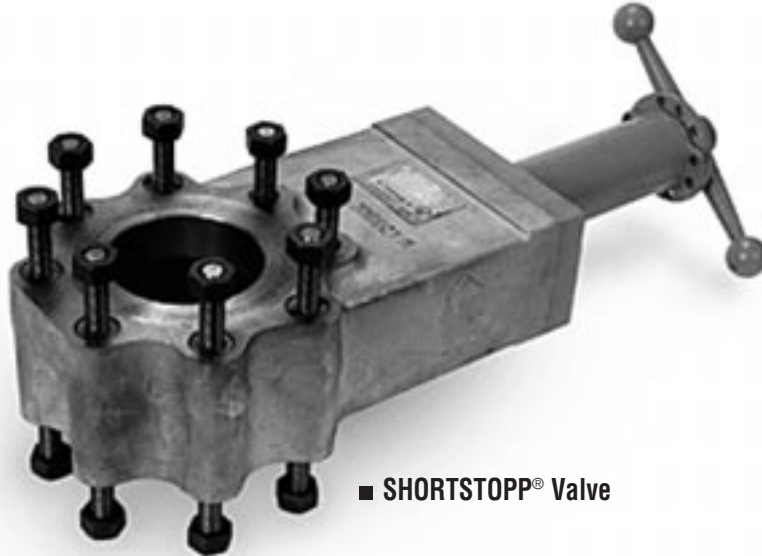

■ **SHORTSTOPP® Valve**

### Description

TDW's line of distribution valves includes the SHORTCUTT® 500 Valve, SHORTCUTT® Valve and SHORTSTOPP® Valve. All are designed for use with the SHORTSTOPP® Plugging Systems for Hot Tapping and SHORTSTOPP® Plugging Operations.

They are temporary valves that are used with TDW drilling or tapping machines and SHORTSTOPP® Plugging Machines. Their compact size reduces the travel required for the drilling machine's boring bar to make taps. The valves are full opening, permitting passage of TDW drills, hole saws, cutters, plugging heads and completion plugs.

### Features

The SHORTCUTT Valve body is constructed of pressure-quality cast iron. The SHORTSTOPP Valve body is constructed of aluminum. SHORTCUTT 500 Valves are constructed of ductile iron.

The 2" and 3" (DN 50 and DN 80) SHORTCUTT 500 Valves replace the SHORTCUTT 2" and 3" valves to accommodate higher pressure lines. The maximum working pressure is 500 psi at 100°F (35 bar at 38°C) or 460 psi at 180°F (31 bar at 82°C).

The SHORTCUTT Valves accommodate 4" through 12" (DN 100 - DN 300) lines. The maximum working pressure is 275 psi at 100°F (19 bar at 38°C) or 245 psi at 180°F (17 bar at 82°C). These valve sizes meet ASME Class 150 bolt pattern.

The SHORTSTOPP Valves accommodate 2" through 6" (DN 50 - DN 150) lines. The maximum working pressure of the 2" and 3" is 500 psi at 100°F (35 bar at 38°C) or 460 psi at 180°F (31 bar at 82°C). The maximum working pressure of the 4" and 6" is 275 psi at 100°F (19 bar at 38°C) or 245 psi at 180°F (16 bar at 82°C).

### ■ Typical Setup

4" (100 mm) through 12" (300 mm)

SHORTSTOPP® II  
Plugging Machine  
(or tapping machine)

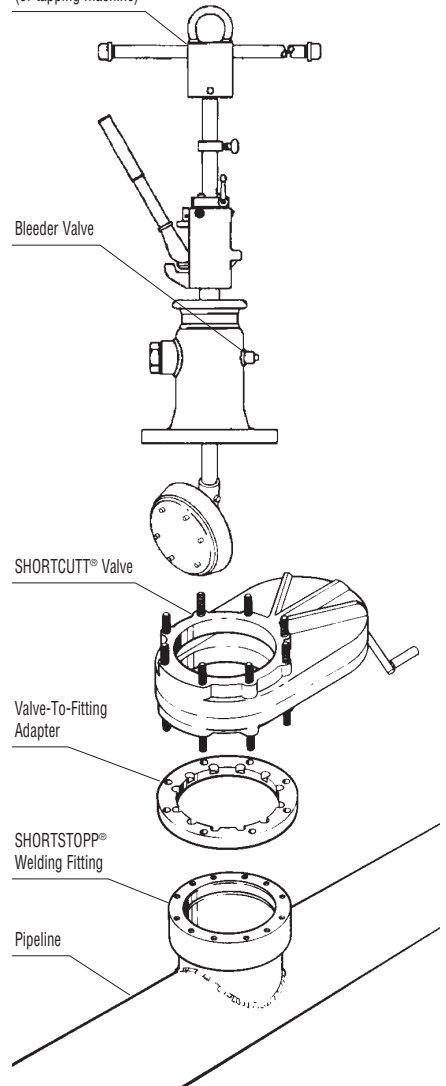

ISO 9001 Certified

Toll Free

**1-888-TDWmSon (839-6766)**



# Distribution Valves



■ SHORTCUTT® 500 2" Ductile Iron Valve



■ SHORTCUTT® 500 3" Ductile Iron Valve



■ SHORTCUTT® 4" - 12" Cast Iron Valve



■ SHORTSTOPP® 2" & 3" Aluminum Valve



■ SHORTSTOPP® 4" & 6" Aluminum Valve

## SHORTCUTT® 500 Valves

Size		Weight		Part Number
Inches	DN	Lbs.	Kg.	
2	50	12.5	6	09-0758-0000
3	80	27	12	09-0759-0000

## SHORTCUTT® Valves

Size		Weight		Part Number
Inches	DN	Lbs.	Kg.	
4	100	78	35	09-0040-0000
6	150	142	64	09-0041-0000
8	200	207	94	09-0042-0000
12	300	454	206	09-0044-0000

Includes operating handles

## SHORTSTOPP® Valves

Size		Weight		Part Number
Inches	DN	Lbs.	Kg.	
2	50	12	5	09-0694-0000
3	80	24	11	09-0695-0000
4	100	50	23	09-0696-0000
6	150	75	34	09-0697-0000

# Distribution Valves

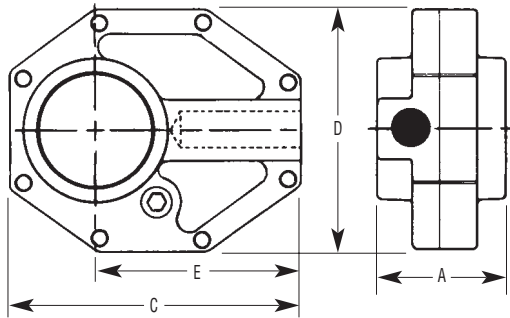

■ 2" (50 mm) and 3" (80 mm)

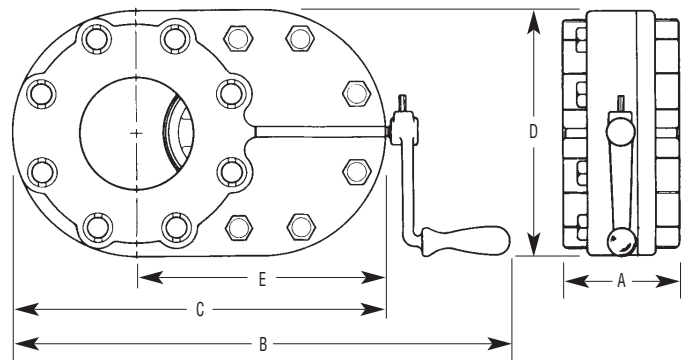

■ 4" (100 mm) and 12" (300 mm)

## SHORTCUTT® 500 Valve Dimensions — 2" and 3" (DN 50 and DN 80)

Size		A		B		C		D		E		Bore	
Inches	DN	Inches	mm	Inches	mm	Inches	mm	Inches	mm	Inches	mm	Inches	mm
2	50	3-3/16	81	--	--	6-5/8	168	5-5/8	142	4-1/4	108	2-7/32	56
3	80	4-1/8	104	--	--	10-1/8	257	7-3/4	196	6-3/8	162	3-1/4	83

## SHORTCUTT® Valve Dimensions — 4" through 12" (DN 100 - DN 300)

Size		A		B		C		D		E		Bore	
Inches	DN	Inches	mm	Inches	mm	Inches	mm	Inches	mm	Inches	mm	Inches	mm
4	100	4-1/4	108	18	457	13-1/2	343	9	229	9	229	4-1/8	105
6	150	5-1/4	133	22-9/16	573	18-1/16	459	11	279	12-9/16	319	6-1/8	156
8	200	5-1/2	140	27	686	22-1/4	565	13-1/2	343	15-11/16	398	8-1/16	205
12	300	6	152	37-5/8	956	32	813	19	483	22-1/2	572	12-1/8	308

## SHORTSTOPP® Valve Dimensions — 2" through 6" (DN 50 - DN 150)

Size		A		B		C		D		E		Bore	
Inches	DN	Inches	mm	Inches	mm	Inches	mm	Inches	mm	Inches	mm	Inches	mm
2	50	2-5/8	67	13-5/8	346	N/A	N/A	4-5/16	110	9-7/8	251	2-1/16	52
3	80	4-5/16	102	19-3/8	492	N/A	N/A	5-3/4	146	15-3/8	391	3-1/4	83
4	100	4-1/2	114	24-3/8	619	N/A	N/A	8-9/16	217	18-1/8	460	4-1/8	105
6	150	5-1/4	133	31-3/4	806	N/A	N/A	10-3/4	273	25	635	6-1/4	159